



5000
Street sweeper **VELOCE**

DULEVO
FAYAT GROUP

Thanks to its exclusive hydraulic technology equipped with a two-speed gear, the Dulevo 5000 Veloce is really versatile and can be used to clean roads, highways, ports, airports, fruit and vegetable markets, and much more.



The Dulevo 5000 Veloce street-sweeper can reach a speed of 70 km/h and is extensively used by town halls and municipalities that need to cover wide distances, so that speed of transfer becomes a crucial point.

Thanks to the Dulevo patented mechanical-suction-filtering system, the Dulevo 5000 Veloce sweeper has a performance three times higher than any other traditional sweeper. The collection is mechanical and is facilitated by the side brushes, which convey the debris toward the centre of the machine, where the cylindrical central brush then sends it at a high speed onto a vertical conveyor. The debris is loaded through the upper part in the refuse container, this way optimizing the loading capacity of the machine. The dust raised by the cylindrical central brush is sucked and kept in the refuse container thanks to the depression in the container itself created by two high-range and high-prevalence suction fans. The peculiar fabric filtering system retains even the thinnest particulates and completes the sweeping cycle, guaranteeing the reintroduction in the environment of clean air only.





In cooperation with Gore® Dulevo developed the only worldwide existing full fine dust filtration sweeper. This mechanical-suctionfiltration system grants with the exclusive application of the Gore® technology a total abatement of PM10 particles.

Further benefits of the filter technology are:

- No maintenance
- Self cleaning effect
- Highest proofed absorbing of PM10 / PM5 / PM2,5 / PM 1
- Granted constant & durable filtering
- 35 % higher airflow
- Resistance against water, oil, fats, chemical agents, etc

GORE dust filters installed in the industrial sweeper have 5 YEARS warranty.

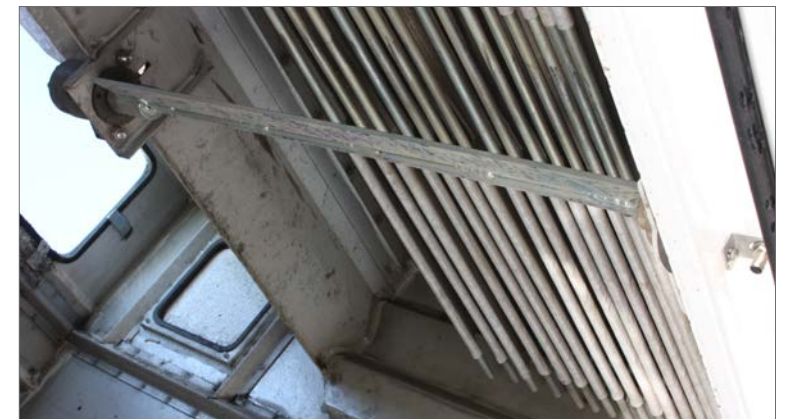



5000

Operators comfort and ergonomics are our priority together with application specifications. Effective axle suspensions and ideal weight distribution insure a balanced and safe drive ability. The powerful drive transmission guarantees the use in difficult conditions and on slopes too. Hydraulic steering make this road sweeper highly manoeuvrable, even in the most complex situations.





The 180-degree full motion massive front brush is an indispensable auxiliary tool for sweeping corners, gutters and for increasing working width.

The hopper uplifting system allows the discharge of the debris in refuse containers, trucks or in big refuse compactors. A variety of options expand the working spectrum of Dulevo 5000 Veloce everywhere at any time.



5000 VELOCE

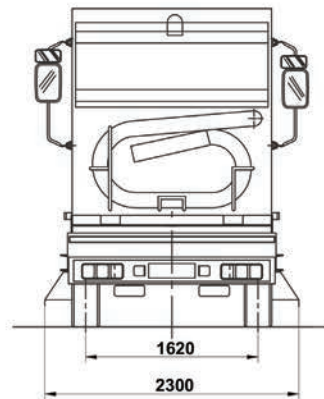
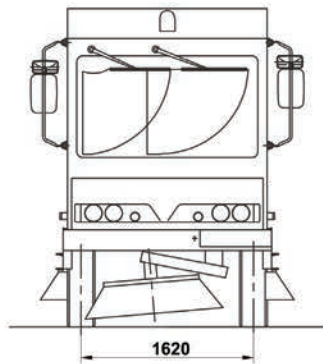
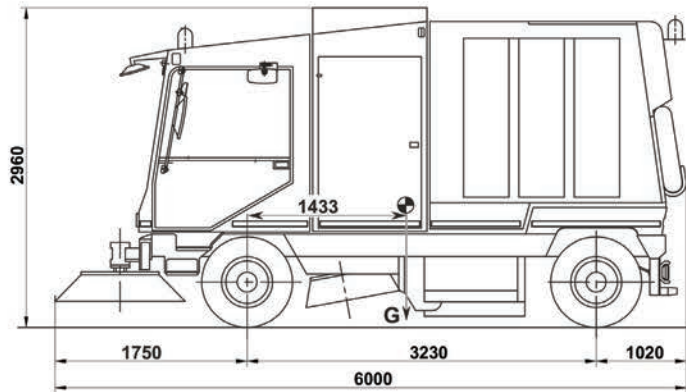

Technical data

5000Veloce

Sweeping width

- With central brush mm 1300
- With central brush and side brushes mm 2600
- With central, side brushes and third brush mm 3500

Container volume m³ 5.3

Dumping height (OPT.) mm 1150 (2400)

Seats in the cabin n° 2

Cleaning performance m²/h 105.000

Maximum speed Km/h 70

Steering diameter (kerb to kerb) mm 13400

Certification PM PM 2,5/PM10****

Engine Brand FPT industrial (Iveco)

Engine Emissions EURO 6 STEP D

Fuel Diesel



COD. F032NI0000 Ed. 00-2021 © (copyright) 2014 Dulevo International S.p.a

Specifications are not binding for our company and subject to change at any time without notice

Dulevo International S.p.A.
Via Giovannino Guareschi, 1
43012 Fontanellato (PR) Italia
Tel: +39-0521-827711
Fax: +39-0521-827795
www.dulevo.com

