



 **DULEVO**
FAYAT GROUP

D3

Street sweeper
High performance
and low consumption

Productivity

4.0 technology

**Quality of life
on board**





Old Town



Cement Factory



Industry



Parking



GDO



City Center



Extra Urban

PRODUCTIVITY

Efficiency and low consumption

It guarantees the highest levels of performance in every context, with lower consumption of water and fuel.



Productivity

Mechanical Filtering Aspirating System

The combination of the mechanical sweeping system and sweeping by suction, supported by a real dust filter, guarantees maximum performance and maximum versatility.

Savings in water and fuel consumption

- Water is only used to cut down on dust on the external brushes. Possibility to work even in the absence of water and great water savings compared to conventional systems.
- Unrivaled ratio of fuel consumption to swept area.

High sweeping performance for high productivity

- Double sweeping speed compared to common technologies.
- Wide Sweeping width.

High filtration efficiency

Dust filter for constant and effective filtration in all conditions.

Reduction of downtime

The limited use of water or the absence of use, makes it possible to drastically reduce or even exclude the H2O refueling times required in conventional systems for PM10 & 2.5 abatement. For dust suppression (double cost).

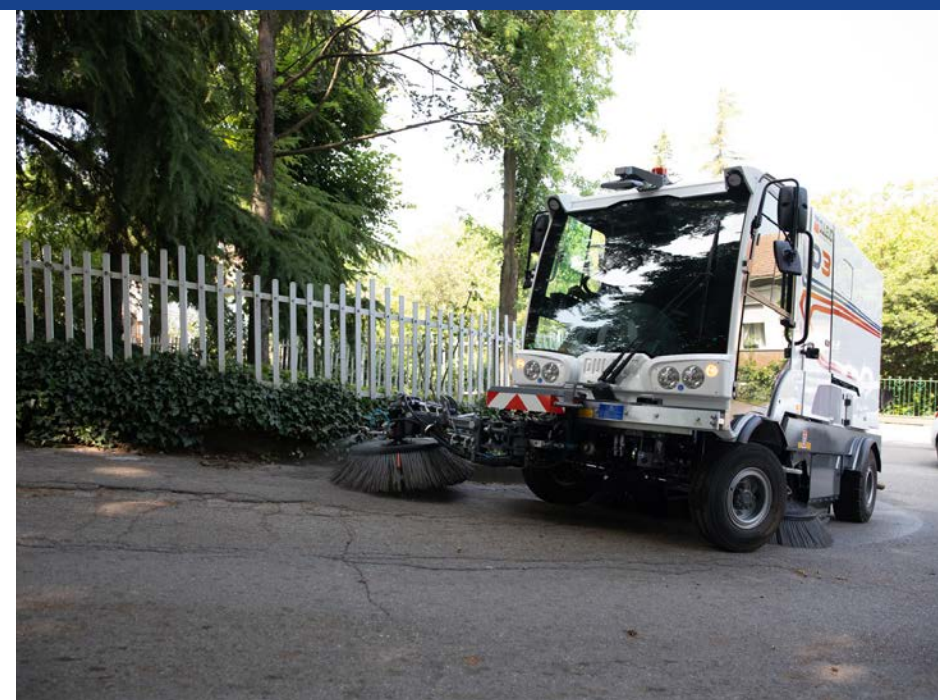



TECHNOLOGY 4.0

Innovation and cutting-edge technology

Innovative features for intuitive and personalized use.

Technology 4.0

Can Bus

In / Out communication system of the sweeping and motor functions on CAN-BUS protocol.

User Friendly Functions

Less time needed to train the operator and the possibility to customize the way the vehicle is used.

Ready for connectivity 4.0 for Smart City

Predisposition for passive and active interface that will allow the development and future implementation in the 4.0 system.

On board diagnostics

- On Board diagnostics directly from the function display.
- Dulevo Telematic remote telemetry in Standard configuration.





QUALITY OF LIFE ON BOARD

Designed for the operator's well-being

An intuitive sweeper, easy to
drive and comfortable even after
many hours of work.

Quality of Life on Board

Comfort in the cabin

- Equipped with two comfortable seats for the operator and the passenger, adjustable and amortized.
- Manual A/C system with controls positioned on the central dashboard.
- Rear security camera screen positioned in the upper part of the cabin in order to allow maximum control during the sweeping phase.

Dulevo AST system

- Easy Start function
- Possibility to select different work programs according to the sweeping conditions: ECO, Normal, Boost.

Standby function

Possibility during the work phases to exit the set work mode and resume it later by pressing the Standby key.

Less noise in the cabin

Noise level in the cabin Less than 66 db.

Sanitation

Possibility of sanitization by photocatalytic oxidation.





Technical Details

Technical Details

Front Brush

- The third front brush is hydraulically controlled in all its functions directly from the operator's position via the new control armrest equipped with Joystick.
- The larger diameter of the front brush allows the sweeping track to be increased.

Engine

- Compliant with Euro 6 C emission standards.
- Mann-Hummel engine filter that guarantees a very high level of protection on three built-in levels:
 - * Vortex prefilter
 - * Main cartridge
 - * Secondary safety cartridge



Technical Details

Water system

- Powered by a stainless steel tank external to the container, with loading hose.
- Water level visible externally through the indicator on the side of the tank.
- Horizontally and vertically adjustable nozzles. The nozzles are equipped with a filter to avoid blockages due to impurities in the water.

Transport

- External part of the conveyor unit in high-strength steel (system invented and patented by Dulevo).
- Conveyor equipped with a system that allows washing with a high water flow through connection to a hydrant. In this way, a perfect cleaning of the belts and vanes from material residues accumulated during sweeping is guaranteed.



Technical Details

Container

- The watertight waste container is made of AISI 304 stainless steel.
- The sweeper is equipped with an inspection hatch and hydraulic hatch opening.
- A Wireless Remote Control is available as an accessory to carry out operations outside the cabin.

Dust filter and filtration certification

- The filter cleaning, by means of a hydromechanical filter shaker, takes place directly from the cabin by means of a dedicated command.
- The D3 sweeper is certified for the retention of fine dust according to the En15429-3 standard.
Possibility to mount Gore filters to increase performance.





Technical data sheet

Technical data		D3
Sweeping width		
- With central brush	mm	1300
- With central brush and side brushes	mm	2150
- With central, side brushes and third brush	mm	3200
Container volume	m ³	3,3
Dumping height (OPT.)	mm	1570 -1730
Seats in the cabin (OPT.)	n°	2
Cleaning performance	m ² /h	90.000
Maximum speed	Km/h	25 - 40
Steering diameter Kerb to Kerb	mm	8300
PM Certification		PM 2,5 / PM10****
Engine Brand		FCA
- FCA Engine emissions		EURO 6 C
Engine Brand		KOHLER
- KOHLER Engine emissions		Tier 3 Decontent / Stage IIIA Equivalent
Engine Brand		KOHLER
- KOHLER Engine emissions		Tier 4
Fuel		Diesel

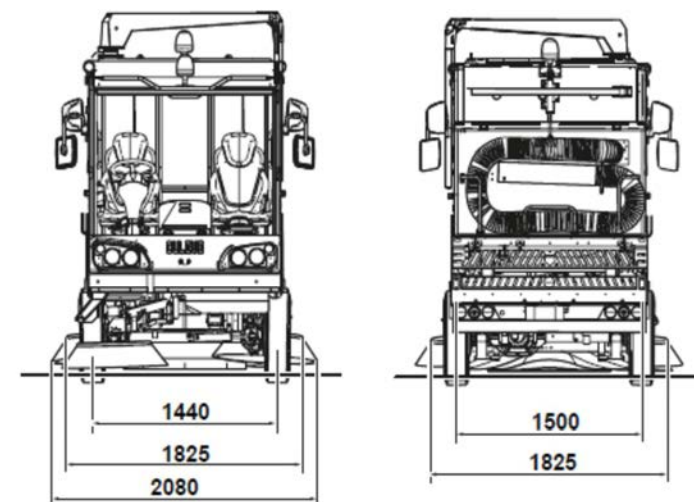
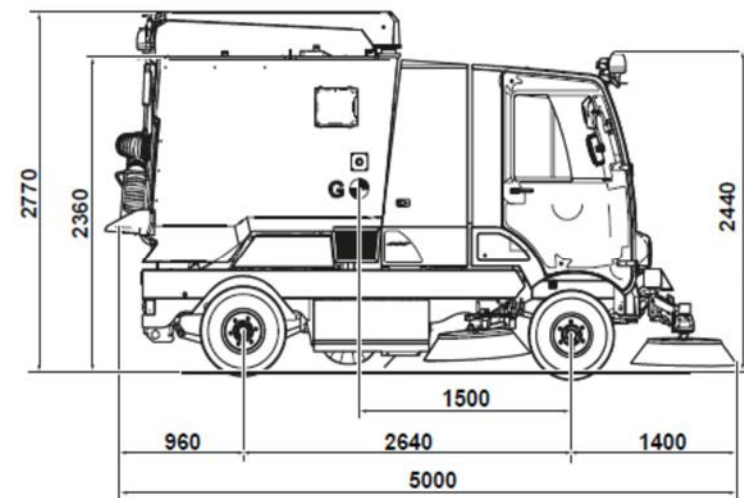



COD. F034E10000 Ed. 00-2021 © (copyright) 2014 Dulevo International S.p.a

Specifications are not binding for our company and subject to change at any time without notice

Dulevo International S.p.A.
Via Giovannino Guareschi, 1
43012 Fontanellato (PR) Italia
Tel: +39-0521-827711
Fax: +39-0521-827795
www.dulevo.com